

UNIVERSAL[®]

CHILLING SYSTEMS

UCS-5AR3-SS AIR COOLED

PHYSICAL DATA

Cooling Capacity	kcal/h		15750
	BTU/h		62600
	Nominal Capacity	RT	5
	Outlet Water Temp.	°F	50
	Condensation Temp.	°F	122
Power Supply			3PH-460V-60HZ
Max Amp		A	12
Total Power Input		HP	7
Power Supply Cable Diameter		mm ²	AWG 11
Safety Protection Device			Overload, Inverse Phase, High/Low Pressure, Water Flow, Water Level & Anti-Freeze Protection
Refrigerant	Type		R410A
	Charge	Lbs	4.0
Compressor	Start Mode		Direct start
	Type		Scroll Type
	Qty		1
	HP		8
	RLA (Rated Load Amp)		8.0
	LRA(Locked Rotor Amp)		62
Fan	Qty		1
	Type		External Rotar Axial Fan
	Power	HP	0.97×1
	Current	A	1.2×1
	LRA	A	7×1
	Volume Air Flow	CFM	5176
Condenser	Type		MCHE
	Subcooling	°F	9
	Heat Rejection	BTU/h	117048
Evaporator	Type		SS304 Shell and Cu Tubes
	Superheat	°F	9
	Heat Rejection	BTU/h	62,600
	Cooled Water Flow	GPM	14
	Water Pressure Drop	PSI	≤12
Energy Adjust Mode			100%-0%
Throttling Device	Mode		thermal expansion valve
Pipe	Water Outlet		MNPT 1"
	Water Inlet		MNPT 1"

UNIVERSAL[®]

CHILLING SYSTEMS

Water Pump	Flow	GPM	14
	Head	PSI	40.6
	LRA	A	6.6
	Power	HP	0.75
Water Tank	Capacity	GAL	25
Sound Pressure at 1 meter	DBA		68
Programming Controller	Display		LCD display
	Controller		microcomputer controller
	Temp Control Range °F		+41 ~+95
	Temp Control Accuracy °F		±3.6
Dimensions	inches (LxWxH)		47×27×46
Weight	lbs		375(For Reference)

NOTES:

- 1 Cooling capacity based on 5°C(41°F) leaving coolant and 35°C(95°F) ambient air.
Chilled water work allowed temperature range: 5°C~35°C (41°F ~95°F).
- 2 Chilled water in and out temperature difference: 3°C~8°C (5.4°F~14.4°F);
Allowed ambient temperature range: -20°C~40°C (-4°F~104°F).
- 3 Power supply: 3PH-460V-60HZ , Allowing the voltage fluctuate ±10%, allow phase voltage difference ±2%, Allow the frequency range ±0.2Hz.

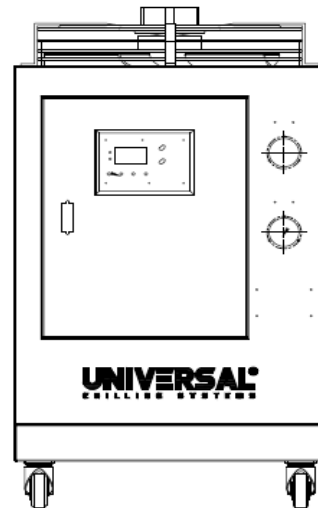
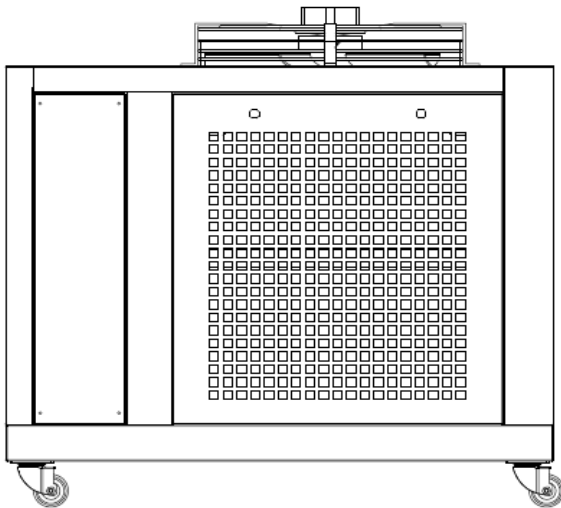

UNIVERSAL[®]

CHILLING SYSTEMS

